

ASPIRE

020 3744 0704
support@aspire-doors.co.uk

44MM & 54MM EXTERNAL FRENCH DOORS

INSTALLATION INSTRUCTIONS

TAKE NOTE

Please ensure all components are in good condition before you start.

Only fit this set using the supplied framework and hardware. Do not attempt to install in unspecified configurations. Failure to adhere to this will invalidate your warranty.

Ensure all timber components are painted or stained before you start.

PLEASE BE AWARE

This set must be installed by two competent trades-people.

Please ensure your structure is capable of supporting these doors.



BEFORE YOU BEGIN

You will need:

- Waterproof high-bond adhesive
- G clamps
- Plastic packers
- Power drill and driver
- Drill bits
- Pozidrive screw driver bit
- Multi-purpose saw

! Please ensure that all unfinished timber components are fully treated with a suitable paint or stain before you begin installation. Failure to do so will invalidate your product guarantee, and will greatly reduce the lifespan of the doors.

SYSTEM OVERVIEW

EXAMPLE 1.8M SET

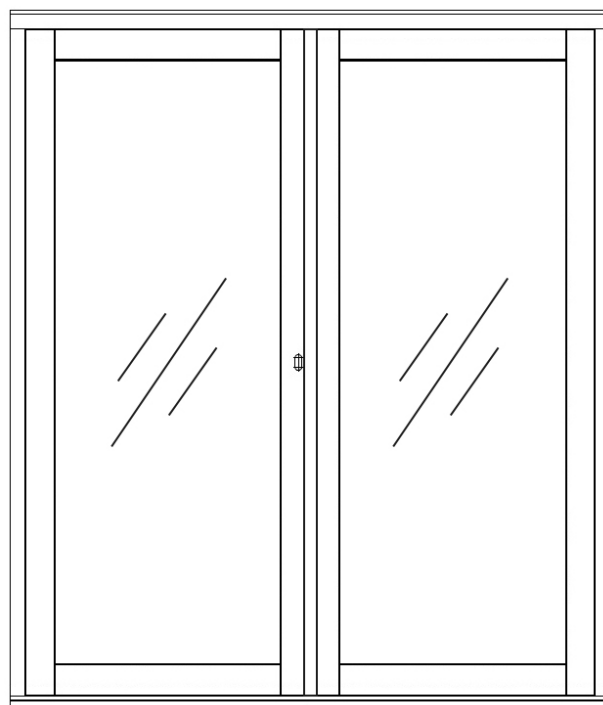
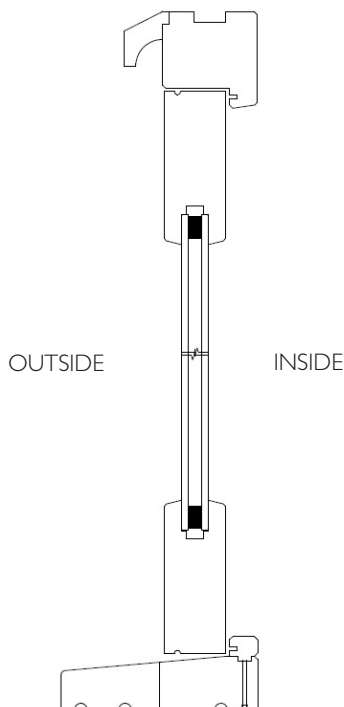

FRAME COMPONENTS

Please check the contents of your frame pack against the relevant items below.

FRENCH DOORS - NO SIDELIGHTS

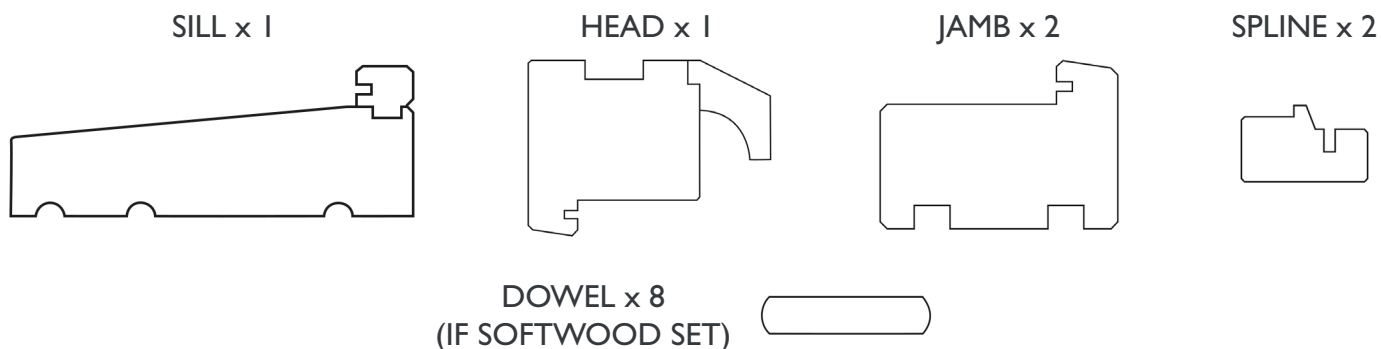

FRENCH DOORS - WITH SIDELIGHTS

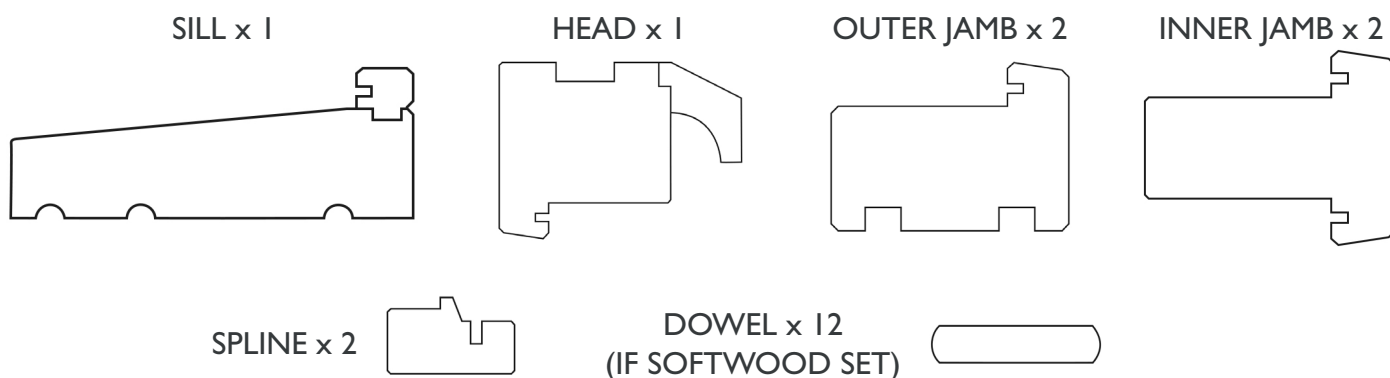

HARDWARE COMPONENTS

COMPONENT	QTY
Trickle Vents	2
Foam Grills	2
Multi-Point Lock	1
Butt Hinges	6
Shootbolts	2

COMPONENT	QTY
Pair of Handles	1
Short Tongue Keep	1
Deadbolt Keep	2
Cylinder Lock & Keys	1
Fixing Pack	1

PREPARE THE APERTURE & FRAME

Use the tables below to build your aperture to the correct size for your set, ensuring the opening is square.

If your set includes fixed sidelights, cut the frame head and sill by the stated amount from each end.

Any cut edges must be treated before installation continues in order to protect against moisture ingress. Failure to do so will invalidate the product guarantee.

Please be aware: assembled frame and required aperture sizes are slightly different for 44mm and 54mm French doors. Ensure you use the correct table for your set.

If you are unsure of whether you have a 44mm or 54mm set, simply measure the thickness of one of your door panels.

54MM FRENCH DOORS - NO SIDELIGHTS

PRODUCT WIDTH	CONFIG.	REQUIRED APERTURE	ASSEMBLED FRAME
1200mm	French pair only	1200mm (w) x 2100mm (h)	1190mm (w) x 2090mm (h)
1500mm	French pair only	1500mm (w) x 2100mm (h)	1490mm (w) x 2090mm (h)
1800mm	French pair only	1800mm (w) x 2100mm (h)	1790mm (w) x 2090mm (h)

44MM FRENCH DOORS - NO SIDELIGHTS

PRODUCT WIDTH	CONFIG.	REQUIRED APERTURE	ASSEMBLED FRAME
1200mm	French pair only	1210mm (w) x 2100mm (h)	1200mm (w) x 2090mm (h)
1500mm	French pair only	1510mm (w) x 2100mm (h)	1500mm (w) x 2090mm (h)
1800mm	French pair only	1810mm (w) x 2100mm (h)	1800mm (w) x 2090mm (h)

54MM FRENCH DOORS - VESTIBULE FRAME WITH SIDELIGHTS

PRODUCT WIDTH	CONFIG.	REQUIRED APERTURE	REQUIRED ASSEMBLED FRAME	HEAD & SILL SUPPLIED LENGTH	TRIM EACH END OF HEAD & SILL BY
2100mm	1200mm pair + 2 x 450 sidelights	2100mm (w) x 2100mm (h)	2090mm (w) x 2090mm (h)	2390mm	150mm
2400mm	1200mm pair + 2 x 600 sidelights	2400mm (w) x 2100mm (h)	2390mm (w) x 2090mm (h)	2390mm	No cut required
2400mm	1500mm pair + 2 x 450 sidelights	2400mm (w) x 2100mm (h)	2390mm (w) x 2090mm (h)	2690mm	150mm
2700mm	1500mm pair + 2 x 600 sidelights	2700mm (w) x 2100mm (h)	2690mm (w) x 2090mm (h)	2690mm	No cut required
2700mm	1800mm pair + 2 x 450 sidelights	2700mm (w) x 2100mm (h)	2690mm (w) x 2090mm (h)	2990mm	150mm
3000mm	1800mm pair + 2 x 600 sidelights	3000mm (w) x 2100mm (h)	2990mm (w) x 2090mm (h)	2990mm	No cut required

ASSEMBLE THE FRAME

Use the relevant section below to assemble your set, either French Doors - No Sidelights or French Doors - With Sidelights. **Please read through all steps before beginning frame assembly.**

FRENCH DOORS - NO SIDELIGHTS

Please be aware: Assemble the frame on a level surface. It is recommended that components are laid out to understand their location prior to fixing.

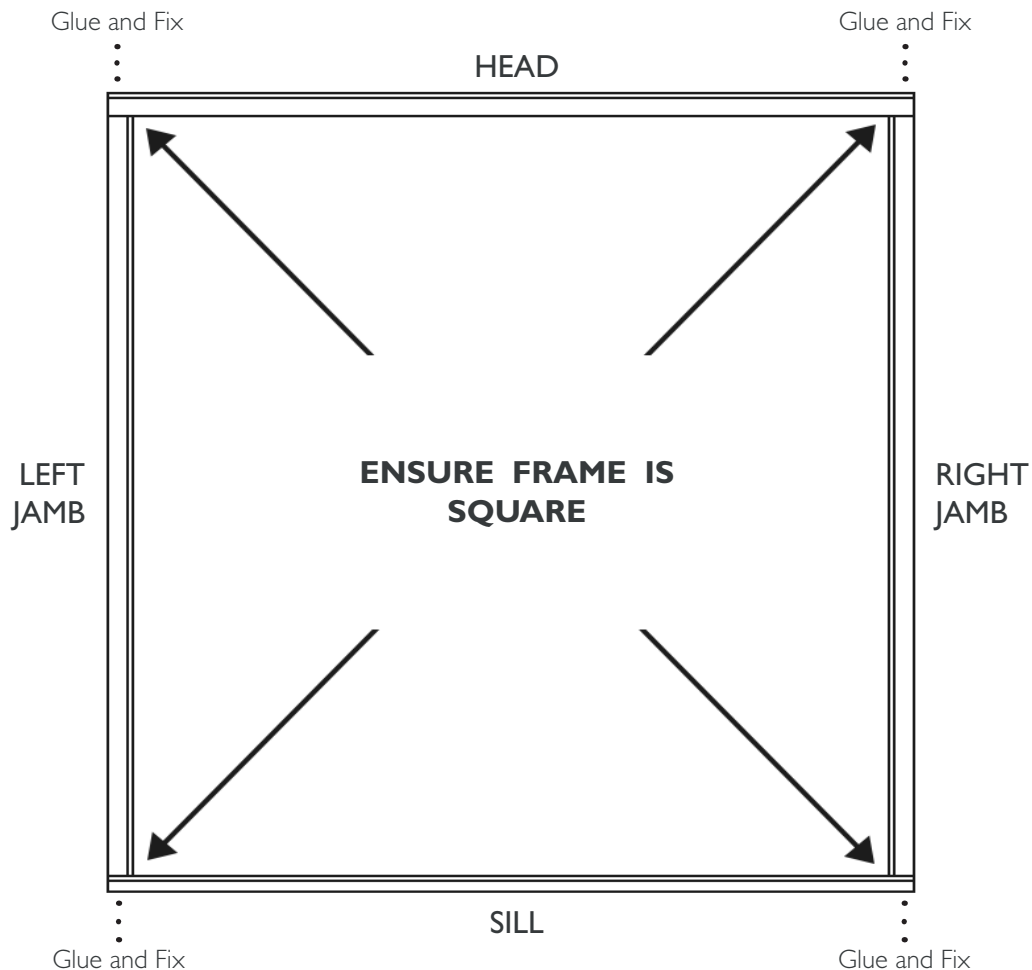

- Identify the left and right hand jambs and locate into the head and sill. Oak door sets use tenon joints, while softwood sets use dowels. Ensure tenons are slotted tight with no gaps. If dowels are very tight, use a drill to ease the hole - **Do not hammer sections together.**

There must not be any weather seals trapped in between frame components. Trim seals if required.

- Glue all meeting faces with your waterproof high bond adhesive. Check the frame is square before the adhesive sets. Adjust if necessary.

- Once square, pre-drill and fix through each joint using two 5 x 90mm screws either side of the dowel or tenon. Check the frame is square, and adjust if necessary.

FRENCH DOORS - WITH SIDELIGHTS

Please be aware: Before assembling the frame, ensure you have performed any necessary Head and Sill trimming for your set, as per the table on page 4.

Assemble the frame on a level surface. It is recommended that components are laid out to understand their location prior to fixing.

Sidelights are installed before fitting the frame into the opening.

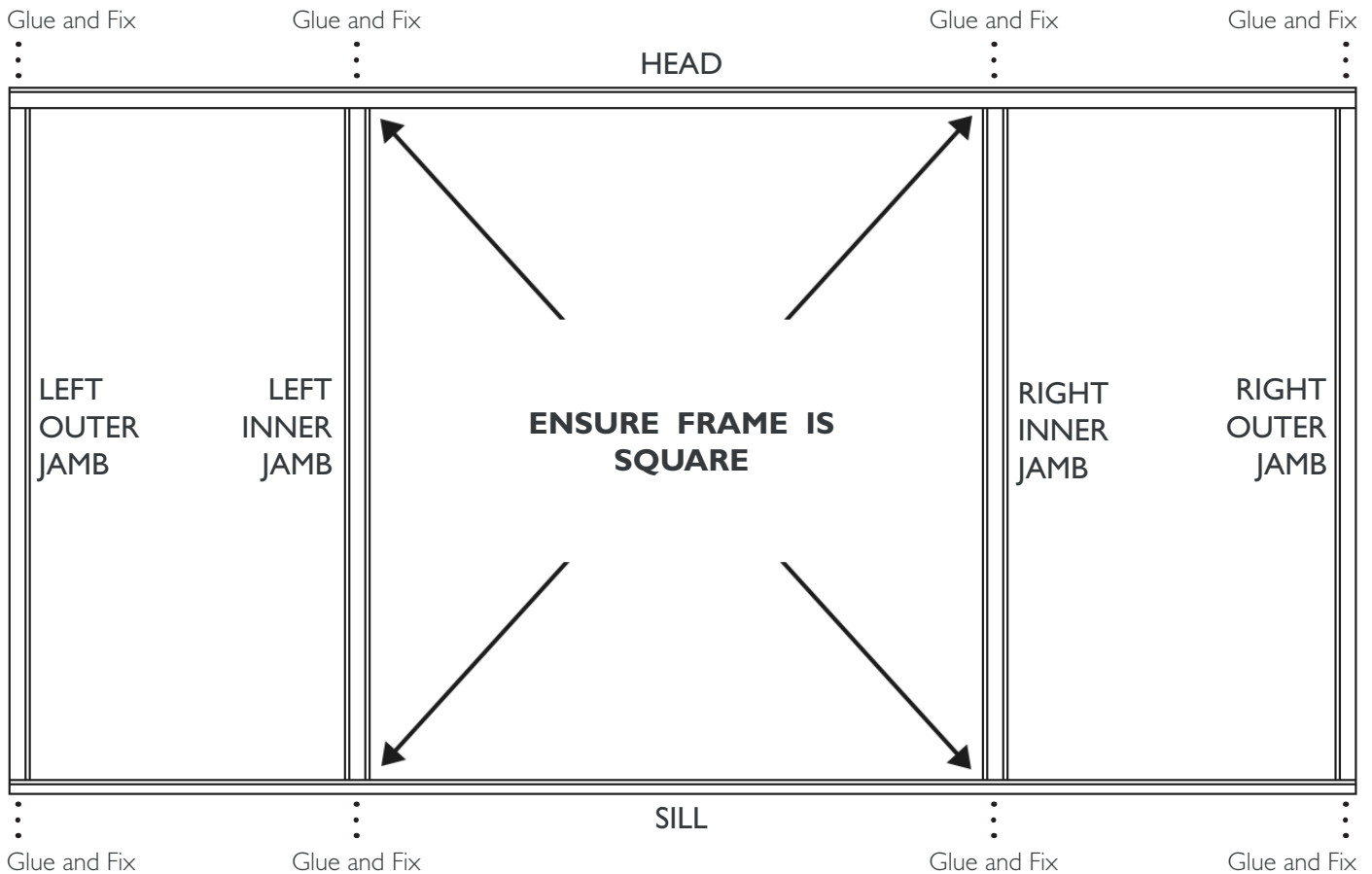

- Identify the inner and outer jambs and locate into the head and sill. Oak door sets use tenon joints, while softwood sets use dowels. Ensure tenons are slotted tight with no gaps. If dowels are very tight, use a drill to ease the hole - **Do not hammer sections together.**

There must not be any weather seals trapped in between frame components. Trim seals if required.

- Glue all meeting faces with your waterproof high bond adhesive. Check the frame is square before the adhesive sets. Adjust if necessary.

- Once square, pre-drill and fix through each joint using two 5 x 90mm screws either side of the dowel or tenon. Check the frame is square, and adjust if necessary.

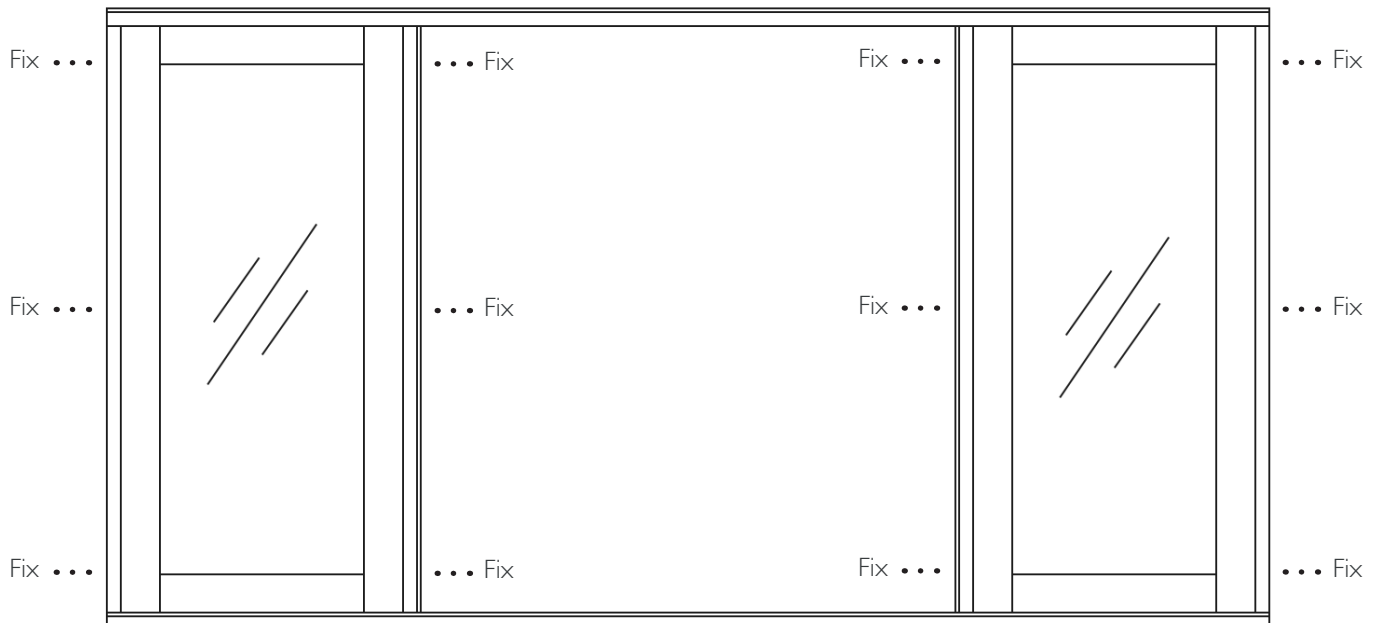

- Lay the assembled frame facing upwards on a flat, level surface and carefully place each sidelight into the frame either side of the central opening.
- The sidelights must be resting against the weather seals around the inside edges of the rebate.
- Pre-drill through the hinge machining on the inner jambs into the sidelights. Countersink and then fix through using woodscrews.
- In similar positions, pre-drill and fix through the outer jambs into the sidelights.

FIT THE FRAME

When moving a frame with sidelights, have at least 2 people to keep the frame square.

- Set the frame in your aperture so the nose of the sill overhangs the outer brickwork. Check levels are square and diagonal measurements are equal.
- For French doors without sidelights, either directly pre-drill and fix through the jambs into the surrounding structure or use tie plates. For French doors with sidelights, tie plates must be used.
- Tie plates are fixed to the back of the jamb and then fixed into the surrounding structure.

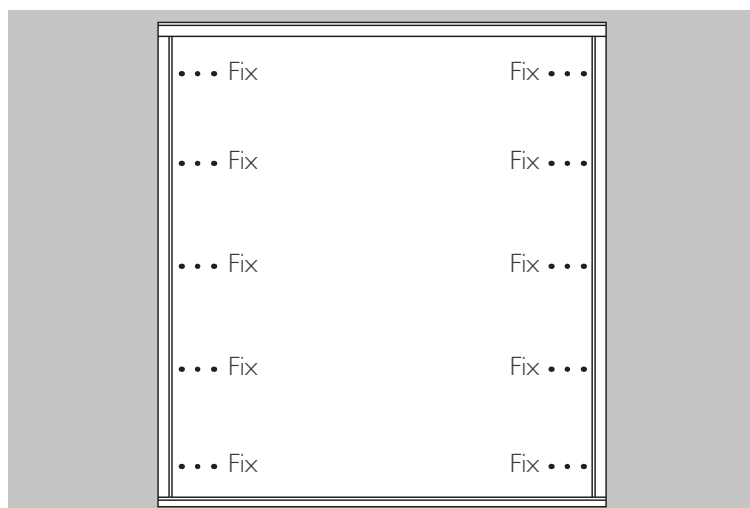

FIT THE BOLTS & KEEPS

Please be aware: the “Lead” door has the multipoint lock inserted. The “Slave” door has been pre-machined for the shootbolts and keeps.

- Using the shootbolts to guide the positions, pre-drill holes in the pre-machined recesses in the Slave door and fix the shootbolts using the screws supplied.

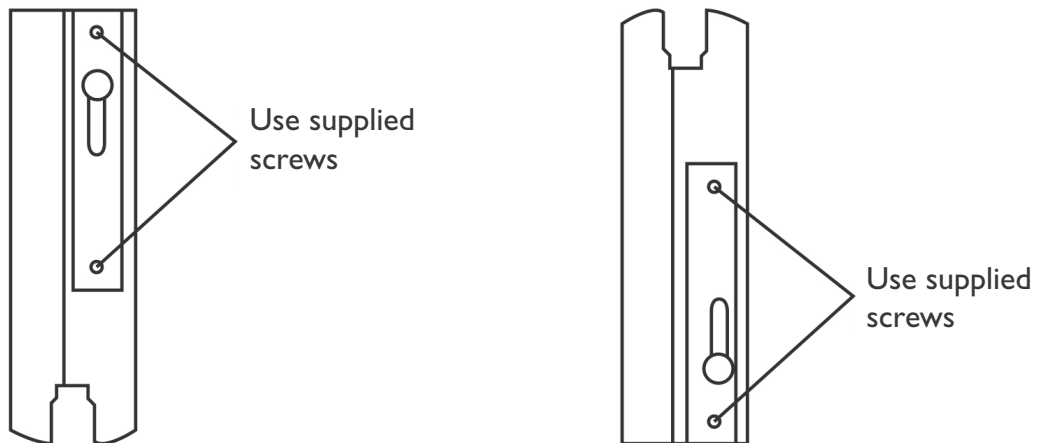

- Pre-drilling and fixing as before, fit the 3 keeps in the side of the slave door using 4.0 x 40mm screws.

The upper and lower keeps are reversible and can be rotated 180 degrees after installation to provide adjustment if necessary. Fit initially with the narrow edge on towards the inside face of the door.

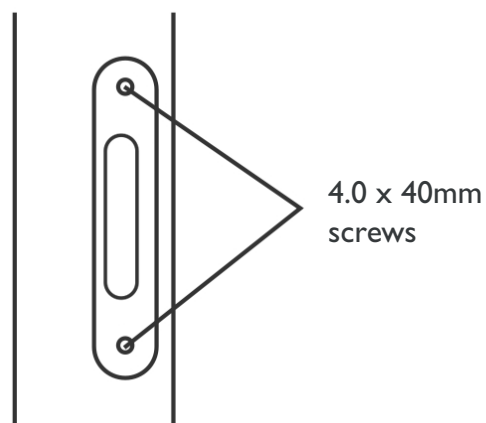

Do not fit the keeps in the head and sill at this point. This is done towards the end once installation is nearly complete.

HANG THE DOORS

Before you proceed, you must determine the desired handing of your set.

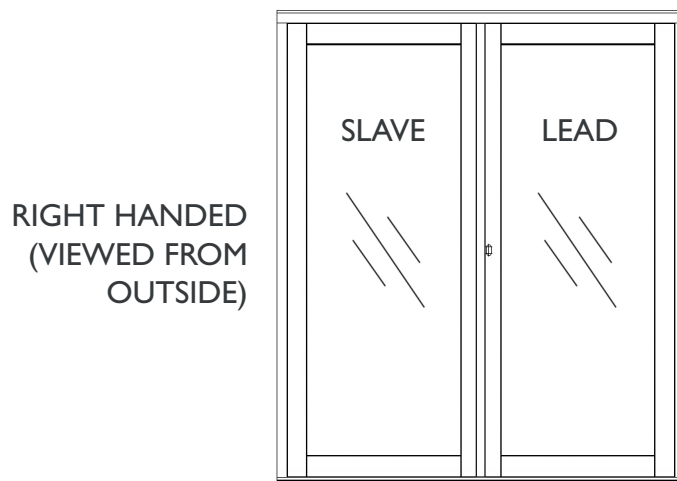
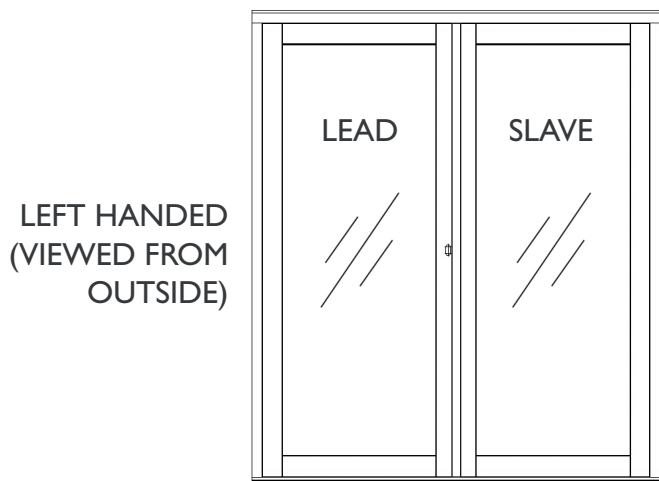

To reverse the handing of the set, simply rotate each door by 180 degrees.

- Using a hinge as a template, pre-drill the pre-machined recesses in the frame jambs and on each door panel.
- First fix the hinges into the frame jambs using the 4.0 x 40mm screws, then offer up the pre-drilled doors and fix using more 4.0 x 40mm screws.

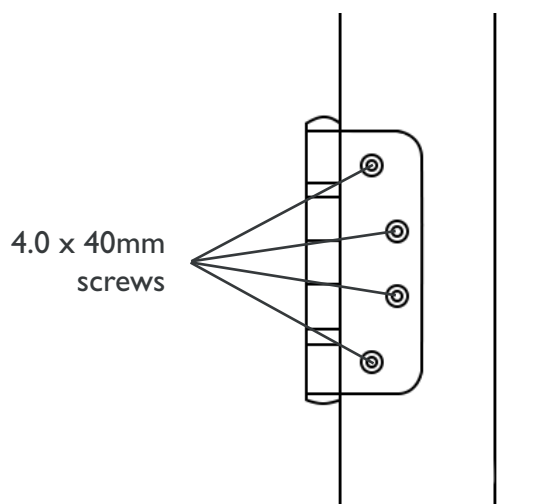

FIT THE HANDLES

- Remove the multi-point lock (MPL) from the edge of the Lead door, if not already done so. Use the diagram below (or template if provided) to cut out for the lock cylinder and lower handle fixing.

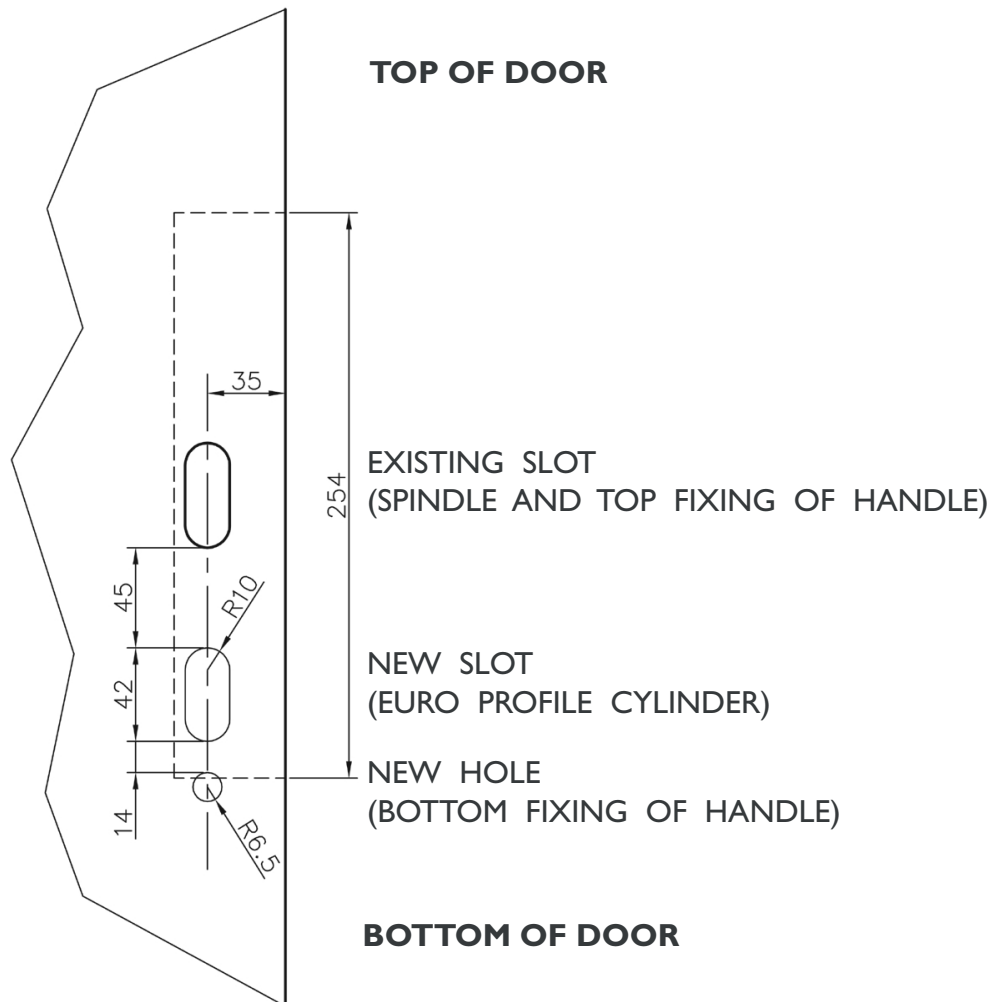

- Insert the MPL into the door and lock cylinder through the drilled hole, then fix in place.
- Insert the handle spindle and attach the handles, with the handle fixing screws on the inside of the property.
- Test the functioning of the MPL and cylinder, then test alignment by closing the Lead door onto the Slave door and engaging the lock. Adjust alignment of the lock or Slave door keeps as necessary.

FIT THE FRAME KEEPS

- Close the Slave door and engage the shootbolt into the timber recess.
- Press the Slave door snug against the weather sealed frame rebate to assess the required keep positions, and fix the keep plates as necessary.

FIT THE COVER SPLINES

Please be aware: the cover splines are slightly different lengths. The longer spline is the external cover spline, and the shorter is the internal cover spline.

- Using your waterproof high-bond adhesive, glue and clamp the external cover spline to the external face of the Lead door and the internal cover spline to the internal face of the Slave door.

It is essential that the splines are fitted straight and square with the faces of the doors. Take care when clamping, and ensure the splines do not rotate inwards.

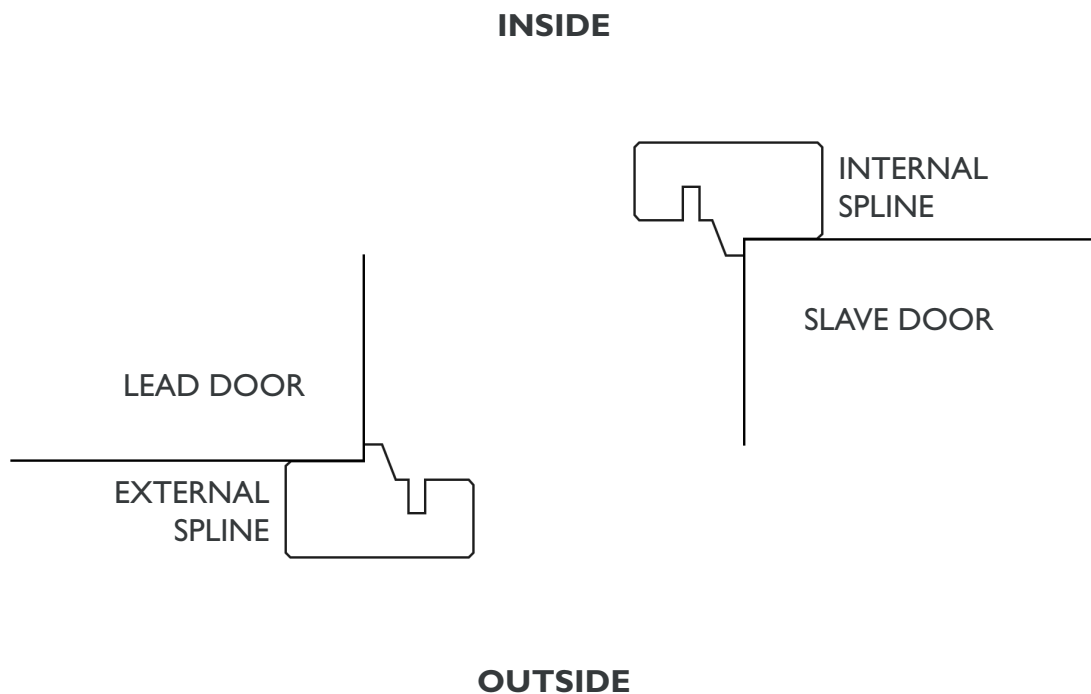

FIT THE TRICKLE VENTS

- Place the foam grills into the vents in the frame head, and fix the vent covers over the opening.

CARE & MAINTENANCE

Hardware is subject to deterioration from everyday use and from the environment that it is in. In particular, it is important that routine maintenance be carried out in industrial applications.

Hinges

Wipe down the visible surfaces with warm soapy water on a soft cloth and then rinse off by wiping with a clean damp cloth. Application of a thin film of a light machine oil or a corrosion preventative spray will help maintain the original lustre of the metal finish. Be careful not to get these compounds on the timber itself as they may cause staining.

Shootbolts

Spray application of a suitable lubricant into the sliding pin inside the bolt and to the lock cylinder. A tube attached to the nozzle will help to concentrate the spray. There are access holes / slots on all shootbolts so this can be achieved without removing the bolts from the doors.

Handles

Refer to the leaflet in the supplied box,

General

Inspect all fixing bolts for tightness every six months, including those securing brackets. Tighten if necessary. Routinely check for wear and if excessively worn, the part should be replaced. Keep the timber and glass clean by using a moist lint-free cloth.

Frequency

The procedures mentioned above need to be carried out as often as is necessary to prevent deterioration in the installed environment, however we recommend the following minimum frequencies:

- General environments 6 monthly
- Marine and industrial environments 3 monthly